

Truck Mounted Attenuators

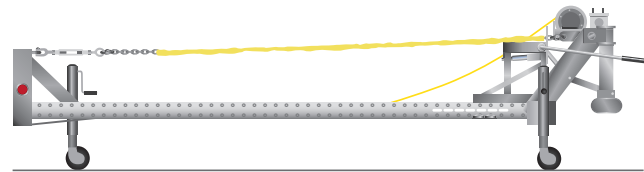

MPS 350[®] X



TRINITY
HIGHWAY

Ahead of the Curve[™]

MPS 350[®] X

The MPS 350[®] X is a galvanized, cantilevered truck mounted attenuator available for use on stationary or moving shadow support vehicles. This compact TMA has passed all mandatory and optional testing and is NCHRP Report 350 Test Level 3 compliant. It has also passed the British high speed standard TD 49 (110km/h). The unit is made of galvanized steel components with an open design, which allows for easy inspection and maintenance. The MPS 350 X helps to absorb rear-end impacts at speeds up to 62 mph when impacted according to NCHRP Report 350 crash test standards.

Assembly and Maintenance

- Compact system allows for easy transport and staging.
- Swivel jacks and casters enable easy mobility around yard.
- Open structure facilitates easy repair, keeping all parts within view and reach.
- Replaceable bump stops are easy to maintain.
- Contained debris field when impacted according to NCHRP Report 350 testing criteria.

ALL GALVANIZED STEEL

Features

- Fully galvanized system. Black and yellow powder coated systems available.
- Open structure allows for easy inspection and less wind resistance.
- Durashell[®] strike plate cover made of heavy-duty plastic provides nuisance hit protection.
- Mounting options include fixed tailgate hitch and socket hitch receiver.
- Improved winch design and motor controller with in-cab control options available.
- Warning buzzer alerts crews when unit is not fully deployed or in upright position.
- FMVSS 108 lighting system.

Specifications

- 14' (4.30 m) Operating Position Length
- 12' 5" (3.78 m) Raised Height
- 69" (1.76 m) Width
- 1,680 lbs. (762 kg) Weight

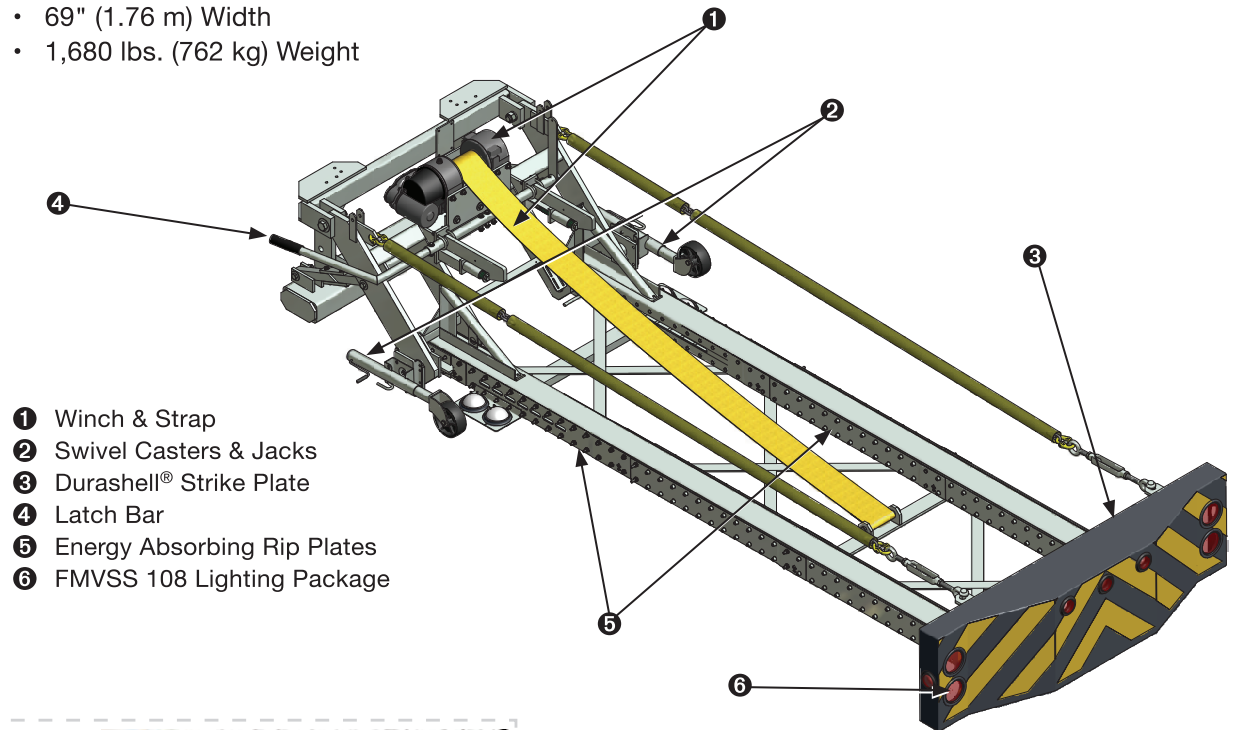

- 1 Winch & Strap
- 2 Swivel Casters & Jacks
- 3 Durashell[®] Strike Plate
- 4 Latch Bar
- 5 Energy Absorbing Rip Plates
- 6 FMVSS 108 Lighting Package

Distributed by:



20 Jones Street
New Rochelle, NY 10801
(914)636-1000



Copyright © 2014 Trinity Highway Products, LLC. All Rights Reserved.

5-14
www.trinityhighway.com
1.888.323.6374