

VULCAN® GATE SYSTEM

QUICK AND
EASY STEEL
BARRIER GATE



OVERVIEW

The Vulcan Gate System from Energy Absorption Systems, Inc. is designed to facilitate access through runs of permanent and temporary longitudinal barrier. The system consists of two steel transitions, two hinges and at least one section of Vulcan Steel Barrier (either 13.5 ft or 40 ft) equipped with wheels and jacks. The gate must use at least one section but can be configured with any number of sections to create the desired opening length.

The Vulcan Gate is NCHRP 350 TL-3 and TL-4 approved and can be used to create an opening in any median or roadside longitudinal barrier. Typical barrier applications include creating emergency cross-over openings in concrete or steel guard rail median barrier, work zone access openings in PCMB and even creating openings in long runs of Vulcan Steel Barrier. No tools or special equipment is required to open and close the Vulcan Gate, the operation is performed completely by hand.



Easily connected and disconnected via a single steel pin

OPERATION

To create an opening, the connecting pins on each hinge are removed to allow the hinge to swing freely. The Vulcan Gate barrier sections are then jacked up onto their wheels with two hand-operated jacks and rolled into the open position. The gate can be opened from either end, from the middle in a "barn door" fashion or completely removed and safely stored out of the way for completely unencumbered access.

FEATURES AND BENEFITS

- Creates an opening in a permanent or longitudinal barrier for emergency or construction zone access.
- Barrier is quickly detached and moved without the need to swing into traffic.
- Opening/Closing operation takes less than 60 seconds.
- Operation of the system is done by hand - no equipment is required.
- Meets NCHRP 350 TL-3 and TL-4 requirements as a longitudinal re-directing barrier.



VULCAN® GATE SYSTEM



SPECIFICATIONS

System Height	32 in.	813mm
System Width	21.5 in.	546 mm
Weight Per Section	1080lb.	490 kg
Minimum Installed Length	30ft	9m
Maximum Installed Length	Unlimited*	

*System length is increased in 13.5 ft. (4m) or 40 ft (12m) increments by inserting additional sections as needed.

- 1 VULCAN BARRIER SECTION
- 2 TRANSITION
- 3 VULCAN GATE HINGE
- 4 CONNECTING PINS
- 5 JACK HANDLES

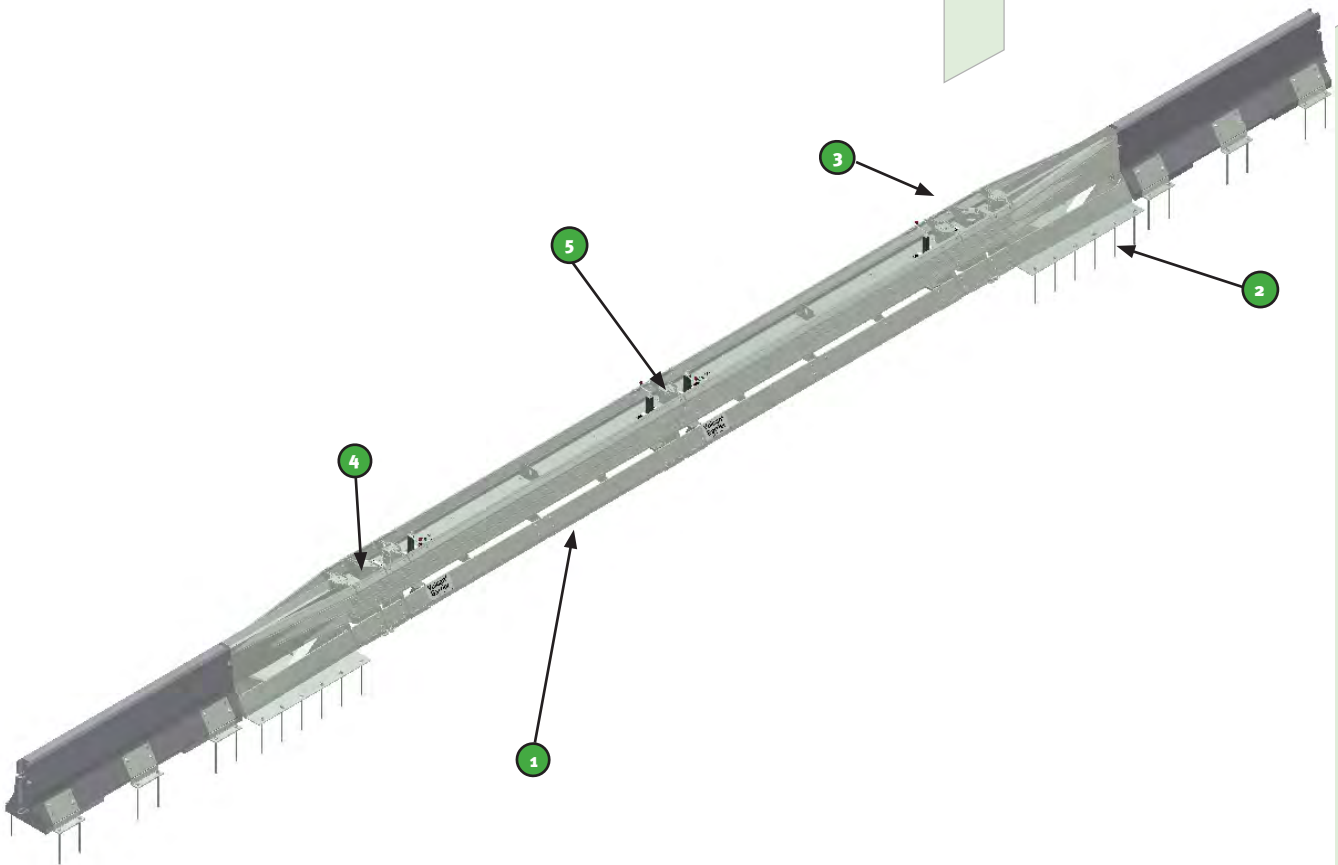

www.energyabsorption.com



General specifications for the ABC Terminal are subject to change without notice to reflect improvements and upgrades. Additional information is available in the Product Manual for this system. Contact Energy Absorption Systems for details