

## PARTS LIST

ITEM	DESCRIPTION	SIZE/SPECIFICATIONS	QTY/ POST	PART NUMBER
1	Bracket, Type AS4	6061-T6 Aluminum	2	SBMAS4*
2	Bracket Hardware Assembly, Type AS4, includes:		1	
2a	Bolt	12.7mm(1/2")-13UNCx184mm(7-1/4"), Hex Head, ASTM A325, Galv. ASTM A153	4	
2b	LockWasher	12.7mm(1/2"), ANSI B18-21-1, Galv. ASTM A153	4	
2c	Nut	12.7mm(1/2")-13UNC, Heavy Hex, ASTM A563 Gr. DH, Galv. ASTM A153	4	
3	Coupling & Special Bolt Assembly, Type A, includes:		1	SB-CALP
3a	Special Bolt	15.9mm(5/8")-11UNC, ASTM A449, Galv. ASTM A153/B695	4	
3b	Coupling	15.9mm(5/8")-11UNC, LP, AMS 6378D, Galv. ASTM A153, Polyester Coat	4	
3c	Shim	15.9mm(5/8") Horseshoe, 14 Gauge, Galv. Steel Sheet	2	
3d	Shim	15.9mm(5/8") Horseshoe, 18 Gauge, Galv. Steel Sheet	2	
4	Anchor Assembly, Type A, includes:		1	SBAAPK
4a	Anchor	15.9mm(5/8")-11UNC, 304 S.S. Ferrule, AISI 1038 Rod, AISI 1008 Coil	4	

\*Complete assembly includes line items 1-3

### GENERAL NOTES:

1. Break-Safe meets all requirements of "AASHTO Standard Specifications for Structural Supports for Highway Signs, Luminaires and Traffic Signals."
2. Break-Safe Model AS4 is designed to fit 89 mm (3-1/2") and 102 mm (4") steel or aluminum square tube signposts.
3. All hardware items are American Standard sizes, gavanized in accordance with ASTM A153 (hot dipped) or ASTM B695 (mechanically applied).
4. Fasteners, except for special bolt and coupling, are installed with lockwashers, and do not have specific torque requirements. Fasteners should be secured as tight as possible with conventional wrenches, unless noted otherwise.
5. Square-up and level individual components, particularly Anchors to minimize the need for shimming between the Couplings and Anchors.
6. No more than two shims shall be placed under any one coupling. No more than three shims underneath any pair of couplings.
7. Refer to other side of page for complete installation instructions.

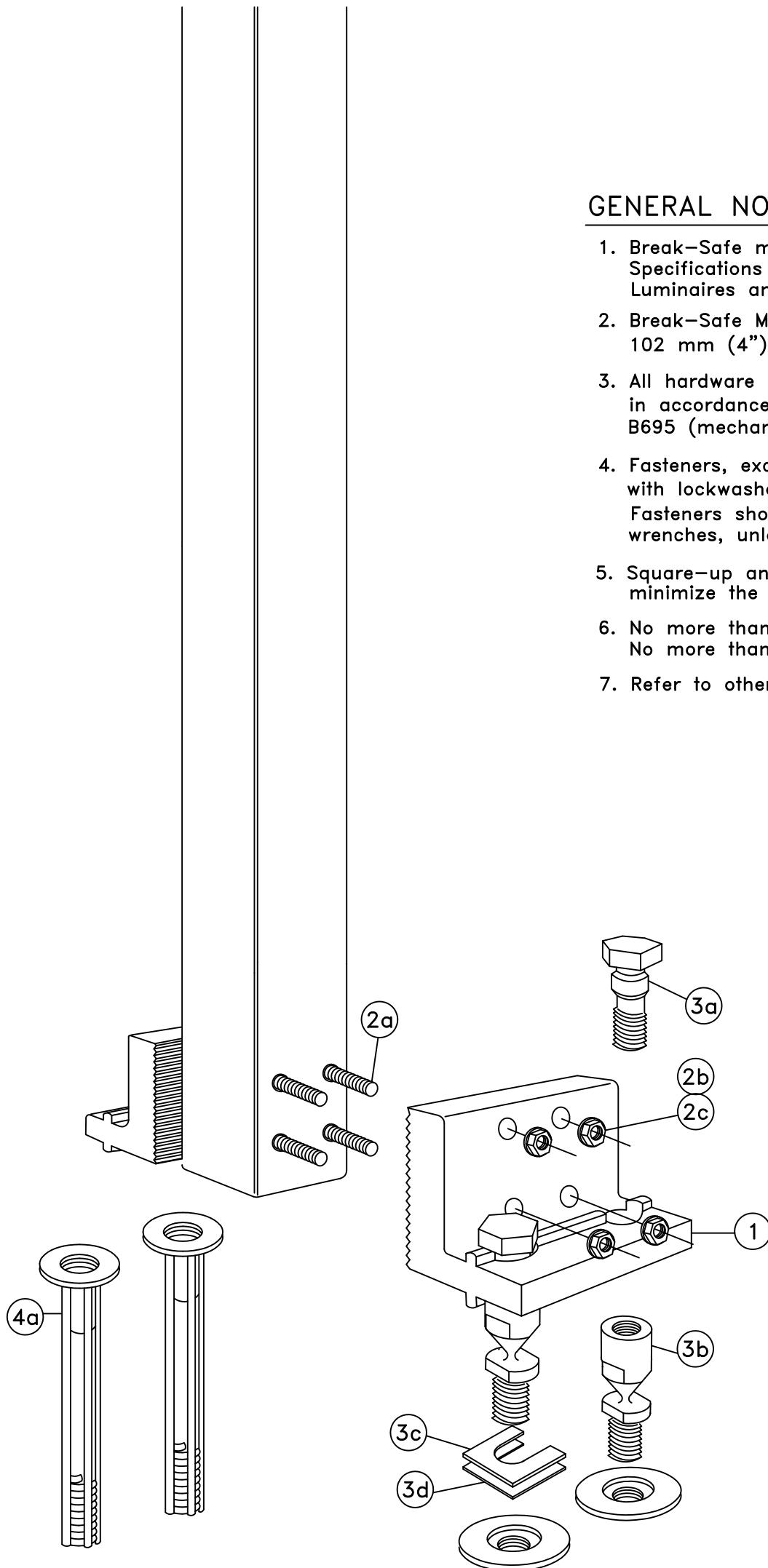

**TRANSPO**® 20 Jones Street  
New Rochelle, NY 10801  
INDUSTRIES, Inc. 914-636-1000  
The Smart Solutions Company www.transpo.com

*Break-Safe Model AS4*  
*Breakaway Support System for Sign Posts*

Scale: Not To Scale

Date: March 2013

Drawing No. BS-AS4-1

Sheet: 1 of 2

Patent Nos. 4,528,786 and 5,596,845

# INSTALLATION INSTRUCTIONS

## ANCHOR ASSEMBLY:

**Note:** Precise positioning of the anchors is critical to proper assembly of the system. It is recommended that actual posts be used to locate the correct position of the anchors.

1. Fabricate a flat, rigid template with four (4) 16mm (5/8") diameter holes located to match the specified anchor pattern of the Break-Safe Brackets attached to the signpost. See diagram below.
2. Attach four (4) Transpo Type A Female Anchors to the template using four (4) 16mm (5/8") diameter bolts. Ensure that each Anchor Washer is snug against the bottom of the template.
3. Lower Anchor Assembly into fresh concrete foundation, and vibrate into position such that the tops of the Anchor Washers are flush with the finished top surface of the foundation. Support the template such that all Anchors are level and in their proper locations.
4. Allow concrete to cure, and then remove the bolts and template from the top of the foundation.

## BRACKET ASSEMBLY:

1. Drill eight (8) 14.3mm (9/16") diameter holes in the bottom end of the post section as shown.
2. Place Brackets squarely on outer surface of the post, and secure with bolts, lock washers, and nuts. Then, tighten all 1/2 turn beyond snug.

## COUPLING ASSEMBLY:

1. Thread four (4) Break-Safe Couplings into Anchors. Do not tighten.
2. Suspend post assembly over foundation, insert Special Bolts through holes in the Brackets, and thread them snug into the Couplings.
3. If post is not plumb, insert Shims (14g and/or 18g) between the Couplings and Anchors, where needed.
4. Use lower wrench flats to tighten Couplings into Anchors as tight as possible using a conventional wrench. Do not use a pipe wrench. Couplings must be seated squarely.
5. Tighten Special Bolts while holding Couplings by the upper wrench flats with an additional wrench to prevent an induced torque stress across the necked portion of the Coupling. All Special Bolts shall also be tightened as tight as possible using conventional wrenches.

## SIGN PANEL ASSEMBLY:

1. After all signposts are secured in place, attach sign panel assembly to posts in accordance with the sign manufacturer's recommendations.

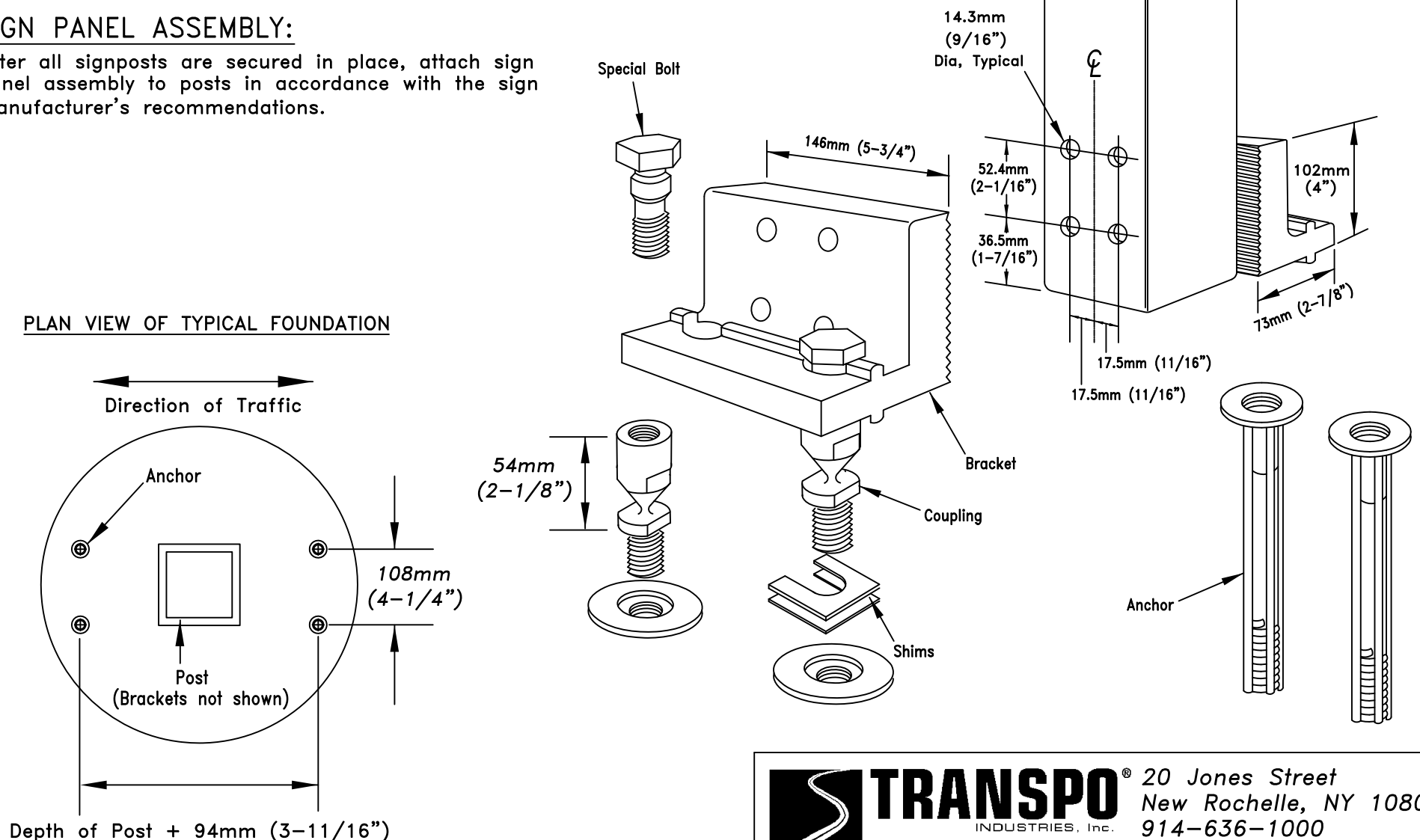

**TRANSPO**® 20 Jones Street  
New Rochelle, NY 10801  
INDUSTRIES, Inc. 914-636-1000  
The Smart Solutions Company www.transpo.com

*Break-Safe Model AS4*  
Breakaway Support System for Sign Posts

Scale: Not To Scale

Date: March 2013

Patent Nos. 4,528,786 and 5,596,845

Drawing No. BS-AS4-2

Sheet: 2 of 2